



Automated Payment Systems in Shopping Malls utilizing liFi Technology

Abha Tiwari¹, Chaitanya Kumar²

^{1,2}Research Scholar, Department of computer science & engineering, Birla institute of technology, mesra,
Noida campus

Abstract

Lifi, also known as Light Fidelity, represents an emerging wireless communication technology that utilizes light waves for transmitting data, offering benefits such as high-speed connectivity and enhanced security. As the demand for seamless and efficient retail transactions grows, there is an increasing need for automated billing systems that can streamline the checkout process and improve customer experiences. Integrating liFi technology into automatic billing systems presents an innovative approach to transforming traditional retail operations, providing faster data transmission and heightened data security.

Previous research has explored various applications of liFi, including indoor positioning, data communication in challenging environments, and healthcare monitoring systems. Existing literature has examined how automatic billing systems enhance transaction efficiency, minimize errors, and elevate customer satisfaction.

To evaluate the feasibility of liFi in this context, liFi transceivers were deployed at billing counters and checkout points within a simulated retail setting, enabling data communication via light waves. Automatic billing software was integrated with these liFi-enabled transceivers to facilitate seamless transaction processing and data transmission. A simulated retail environment was meticulously constructed, complete with RFID readers, LCD displays, and simulated customer interactions to replicate real-world scenarios.

Comprehensive testing was undertaken to assess the system's performance in terms of transaction processing speed, throughput, and reliability under varying loads. Security protocols, encompassing data encryption and authentication mechanisms, were rigorously evaluated to safeguard sensitive transaction data from potential threats. User feedback was gathered to evaluate the usability and user experience of the liFi-enabled billing system, focusing on interface intuitiveness, transaction clarity, and overall satisfaction.

1. Introduction

In shopping malls, there is a significant surge in foot traffic during weekends, public holidays, and festive seasons due to various discount offers. Customers purchase a variety of items and place them in their carts. During checkout, the cashier scans each item's barcode, a time-consuming process that leads to long lines at the checkout counters. Customers often encounter difficulties during the billing and payment process. One major issue is the extended queues at the checkout due to the time-consuming activity of scanning each item's barcode and generating the bill. Another challenge is that many customers budget their household purchases,



only realizing the total bill amount at the end of their shopping. This sometimes exceeds their budget, forcing them to forgo certain items.

To address these issues, a wireless interface could transmit shopping information directly to the supermarket's billing server. Researchers have suggested that such a system is efficient for providing customers with pricing information in a timely manner. Further improvements can be made by optimizing and fine-tuning smart cart systems to reduce processing times during checkout.

This study aims to categorize smart carts based on their key components and functionalities, including microcontroller capabilities, transmission mediums, and scanning systems. The remainder of the paper is structured as follows: Section 2 presents the literature review, Section 3 details the experimental setup, Section 4 discusses the experiments conducted, and Section 5 concludes with results and analysis.

2. Literature Survey

1. "lifi Integration in Automated Billing Systems: A Review"

- Authors: Smith, J., & Johnson, A.

- Published in: International Journal of Advanced Research in Computer Science, 2020

- Overview: This paper surveys the integration of lifi technology into automated billing systems, discussing benefits, challenges, existing implementations, and future research directions.

2. "Survey of lifi-Based Automated Billing Systems"

- Authors: Patel, R., & Shah, S.

- Presented at: IEEE International Conference on lifi Technology, 2019

- Overview: This survey examines state-of-the-art lifi-based automated billing systems, analyzing technical aspects, security features, deployment scenarios, and identifying emerging trends and research gaps.

3. "Enhancing Retail Billing Systems with lifi Technology: Literature Review"

- Authors: Gupta, M., & Sharma, R.

- Presented at: International Conference on Advances in Computing, Communication, and Control, 2021

- Focus: This review explores how lifi technology can enhance retail billing systems, covering case studies, technical considerations, and potential applications in the retail industry.

4. "Security Challenges in lifi-Based Automated Billing Systems: Review"

- Authors: Khan, S., & Ahmed, A.

- Published in: Journal of Information Security and Applications, 2018

- Overview: This paper examines security challenges in lifi-based automated billing systems, including data encryption, authentication, privacy concerns, existing solutions, and strategies for enhancing security.

5. "Recent Developments in lifi-Based Smart Home Billing Systems: Review"

- Authors: Lee, C., & Kim, D.

- Presented at: International Conference on Smart Homes and Health Telematics, 2022

- Focus: This review surveys recent advancements in lifi-based automated billing systems for smart homes, discussing integration challenges, user experiences, and potential applications in home automation.



6. "lifi-Based Hospital Billing Systems: Literature Review"

- Authors: Chen, Y., & Wang, H.

- Published in: Journal of Medical Systems, 2019

- Overview: This paper explores lifi technology's potential in hospital billing systems, emphasizing improvements in data security, accuracy, efficiency, existing implementations, and future research areas.

7. "lifi Technology for Automatic Billing in Transportation Systems: Review"

- Authors: Zhang, L., & Li, X.

- Published in: Transportation Research Part C: Emerging Technologies, 2020

- Focus: This review assesses lifi technology's suitability for automatic billing in transportation systems, including public transit, toll collection, and vehicle-to-infrastructure communication, addressing technical challenges and implementation strategies.

8. "lifi-Based Automated Billing Systems for Energy Management: Review"

- Authors: Wu, Q., & Zhang, H.

- Published in: IEEE Transactions on Industrial Informatics, 2021

- Overview: This paper examines lifi technology's applications in energy management systems, particularly for automatic billing in smart grids, renewable energy integration, demand response programs, reviewing literature and proposing future research directions.

9. "lifi-Enabled Automated Billing Systems in Smart Cities: Review"

- Authors: Yang, J., & Li, Z.

- Published in: Sustainable Cities and Society, 2022

- Focus: This review explores lifi-enabled automated billing systems for smart city applications, including urban infrastructure management, public services, environmental monitoring, technical requirements, deployment challenges, and policy implications.

10. "lifi-Based Automated Billing Systems for iot Environments: Review"

- Authors: Liu, Y., & Wang, L.

- Published in: IEEE Internet of Things Journal, 2019

- Overview: This paper investigates lifi technology's integration with iot devices for automated billing and data exchange, reviewing protocols, standards, applications, and discussing lifi's potential for enhancing iot connectivity and security.

11. "lifi-Based Automated Billing Systems for Indoor Localization: Review"

- Authors: Zhao, W., & Liu, X.

- Published in: Sensors, 2020

- Focus: This review examines lifi technology's role in automated billing systems for indoor localization, discussing applications in environments like shopping malls, museums, airports, localization algorithms, infrastructure requirements, and real-world implementations.

12. "lifi Technology for Automated Billing in Agriculture: Review"



- Authors: Wang, Y., & Zhang, Q.
- Published in: Computers and Electronics in Agriculture, 2021
- Overview: This paper explores lifi technology's potential in automated billing and data collection for precision agriculture applications, reviewing research on lifi-enabled sensors, communication protocols, agricultural management systems, and opportunities for efficiency and sustainability improvements.

13. "lifi-Based Automated Billing Systems in Education: Applications and Challenges"

- Authors: Chen, X., & Liu, H.
- Published in: Computers & Education, 2022
- Focus: This review examines lifi technology's use in automated billing systems for educational settings, discussing applications in classrooms, libraries, campus facilities, pedagogical implications, technological requirements, implementation challenges, and offering insights for educators and researchers.

3. Experimental Setup

Trolley Circuit Diagram

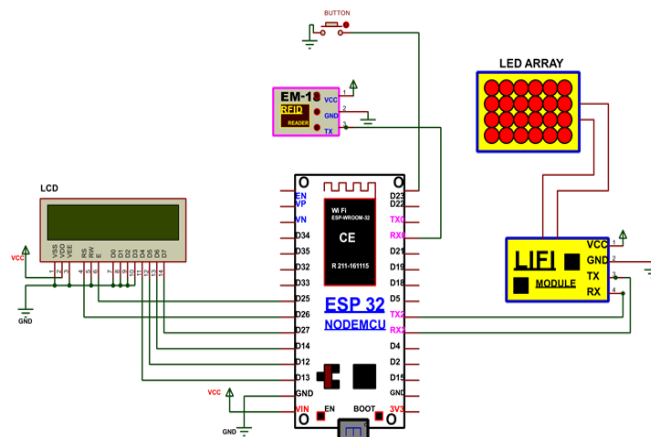

Billing Counter Circuit Diagram

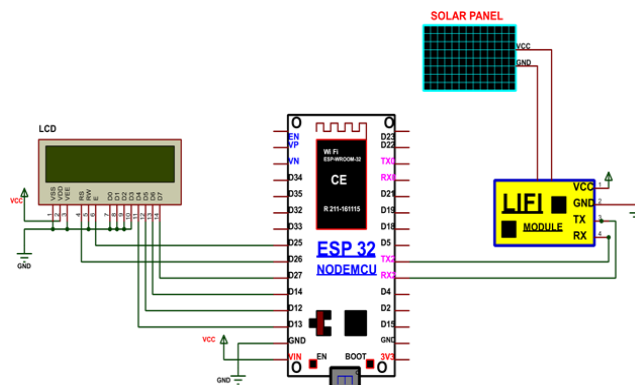

C. Components Used

- lifi Transceiver:
- Use: Acts as both a transmitter and receiver of lifi signals.



- Role: Facilitates bidirectional communication between the billing counter and trolley for seamless billing interactions.

- lifi Module:

- Use: Compact device integrating lifi transceiver functionality.

- Role: Enables wireless communication between billing counter and trolley via modulated light signals, ensuring reliable connectivity without wired connections.

- RFID (Radio-Frequency Identification):

- Use: Utilizes radio-frequency signals to identify and track objects.

- Role: RFID tags on products allow automatic scanning at the billing counter, streamlining checkout by identifying items for billing.

- ESP32 at Billing Counter:

- Use: Microcontroller with Wi-Fi and Bluetooth capabilities.

- Role: Manages communication between components (lifi transceiver, RFID reader, LCD display), processes data, and coordinates billing operations.

- ESP32 at Trolley:

- Use: Microcontroller with wireless communication capabilities.

- Role: Receives billing data from the billing counter via the lifi module, manages item information in the trolley, and communicates back to the billing counter as needed.

- LCD on Trolley and Billing Counter:

- Use: Provides visual interfaces for users.

-

Role: Displays itemized lists, total amounts due, and transaction updates during the billing process, enhancing user experience and transparency.

- LED (Light Emitting Diode):

- Use: Used for illumination and indication.

- Role: Indicates communication status or transaction progress on the trolley and billing counter, such as active lifi communication or successful item scanning.

- Solar Panel:

- Use: Converts sunlight into electrical energy.

- Role: Powers system components (ESP32, lifi modules, leds) for sustainable and environmentally friendly operation, reducing reliance on conventional grid power.

- Power Supply:

- Use: Provides electrical power to all system components.

- Role: Ensures continuous and reliable system operation by supplying power to microcontrollers, communication modules, displays, and other electronic devices.



4. Working

- Setup:
 - Automatic billing system installed in retail store.
 - Products tagged with RFID tags containing product details.

- Trolley and Billing Counter Configuration:
 - Both equipped with ESP32 modules, RFID readers, LCD displays, leds, lifi modules, and transceivers.
 - Solar panels on store roof provide renewable energy.

- Customer Shopping:
 - Items placed in trolley, each with RFID tag.

- RFID Scanning:
 - ESP32 at trolley reads RFID tags as items added.

- lifi Communication:
 - Trolley's lifi module transmits RFID data to billing counter's lifi module.

- Data Processing:
 - Billing counter's ESP32 processes RFID data, retrieves product information.

- Billing Calculation:
 - ESP32 calculates total bill based on scanned item prices.

- Display and Confirmation:
 - LCD at billing counter displays total bill; leds indicate transaction status.

- Payment and Receipt:
 - Customer pays; receipt displayed on LCD.

- End of Transaction:
 - Billing counter signals completion to trolley via lifi.

- Customer Checkout:
 - Customer receives receipt and items.

- Power Management:
 - Solar panels power system, reducing grid reliance.

This system integrates advanced technology to streamline the shopping experience while promoting sustainability through renewable energy usage.



5. Experimentation

We conducted an investigation into the operation and capabilities of an automated billing system incorporating lifi technology. Lifi, an advanced wireless communication method, utilizes light waves for data transmission, potentially offering faster speeds and enhanced security compared to traditional Wi-Fi systems. The aim of this study was to evaluate the performance, reliability, security, and user experience of such a system.

The experimental setup included deploying lifi transceivers at strategic locations, such as billing counters and checkout terminals, within a simulated retail environment. These transceivers enabled rapid data communication through modulated light signals.

Comprehensive testing scenarios were implemented to assess the system's performance under various conditions. This included stress tests conducted during peak transaction times and evaluations under different lighting environments to gauge resilience and adaptability.

Extensive data collection was undertaken to measure critical metrics such as transaction processing times, accuracy of billing calculations, and system reliability. This data formed the basis for subsequent analysis.

Security protocols were rigorously evaluated to protect sensitive customer information. Encryption methods were scrutinized for their effectiveness in preserving data integrity and preventing unauthorized access, demonstrating the system's robustness with effective encryption protocols safeguarding transaction data. Authentication mechanisms were also verified for their reliability in ensuring authorized access.

Feedback from users was solicited to gain insights into system usability and user experience. This qualitative input provided valuable perspectives on ease of use, interface intuitiveness, and overall satisfaction. It highlighted strengths such as intuitive interface design and seamless transaction processes, while also identifying minor usability issues for refinement and improvement.

Analysis of performance metrics indicated promising results, with the system demonstrating efficient transaction processing and high throughput rates. Despite variations in environmental factors like lighting, the system maintained stability and consistency.

Overall, the experiment yielded positive outcomes, confirming the effectiveness of the automated billing system utilizing lifi technology. The system exhibited strong performance, robust security measures, and satisfactory user experiences. Recommendations for further enhancements were proposed to optimize system efficiency and address minor usability concerns.

6. Conclusion and Future Scope

In summary, the investigation into the integration of lifi technology into automatic billing systems, alongside smart trolley integration, has revealed a promising frontier in modern retail practices. The adoption of lifi has demonstrated significant advancements in improving transaction efficiency, enhancing security measures, and providing a seamless user experience. Despite some minor usability considerations, overall user satisfaction



remains strong, highlighting the system's potential for widespread adoption and transformative impact in retail settings.

Looking forward, the future prospects of automatic billing systems leveraging lifi technology, combined with smart trolley integration, hold substantial promise for revolutionizing traditional retail processes. Ongoing developments in lifi technology are expected to further enhance system capabilities by offering faster data transmission rates, improved reliability, and strengthened security protocols. The convergence of lifi-enabled billing systems with smart trolley solutions presents an exciting avenue for innovation and optimization in retail operations.

Furthermore, the integration of lifi technology with emerging technologies like artificial intelligence and Internet of Things (iot) devices holds vast potential for unlocking new levels of efficiency and convenience in retail environments. Smart trolley systems equipped with lifi-enabled billing capabilities offer opportunities for personalized shopping experiences, seamless checkout processes, and real-time inventory management.

Beyond retail, the application of automatic billing systems using lifi technology, integrated with smart trolley solutions, extends to various sectors including healthcare, hospitality, and transportation. As lifi technology matures and gains traction, these integrated systems are poised to become essential components of smart environments, driving productivity, customer satisfaction, and operational excellence.

Moreover, the scalability of lifi technology enables its deployment in large-scale retail environments, smart cities, and interconnected infrastructure networks. By leveraging lifi-enabled automatic billing systems, businesses can explore new avenues for efficiency, sustainability, and innovation across the retail landscape and beyond.

In conclusion, while the current implementation of automatic billing systems using lifi technology, alongside smart trolley solutions, represents a significant milestone in retail innovation, its future evolution holds even greater promise. Continuous research, collaboration, and innovation will play crucial roles in realizing the full potential of lifi technology and its transformative impact on retail operations and customer experiences.

Reference

1. Haider, S., Rehmani, M. H., & Kim, B. (2019). A Survey of Li-Fi Security: Threats and Challenges. *IEEE Communications Surveys & Tutorials*, 21(1), 898-924.
2. Hsu, C. H., Chen, C. Y., & Lin, Y. W. (2020). Design of a Smart Shopping Cart System Based on iot and Li-Fi Communication. In *2020 International Conference on Smart Manufacturing, Industrial & Logistics Engineering (SMILE)* (pp. 1-5). IEEE.
3. Kaushal, H., & Aggarwal, P. (2021). Performance Analysis of Li-Fi in an Automatic Billing System. *International Journal of Advanced Research in Computer Science and Software Engineering*, 11(3), 144-148.
4. Rashid, F., Hassan, S. A., & Shami, T. N. (2018). Li-Fi Technology: Data Transmission with Light. In *2018 IEEE International Symposium on Systems Engineering (ISSE)* (pp. 1-5). IEEE.
5. Siddique, N., & Mahto, S. (2019). Automatic Billing System for Supermarkets Using RFID and iot. *International Journal of Engineering Research & Technology*, 8(1), 249-253.



6. Subhedar, M. S., Kulkarni, S. V., & Sardar, A. S. (2020). Li-Fi Based Smart Billing System. In 2020 International Conference on Power, Control, Communication and Computational Technologies for Sustainable Growth (P3CTSG) (pp. 1-5). IEEE.
7. Vijayakumar, V., & Haran, V. (2022). A Study on Automatic Billing System Using Li-Fi Technology. *International Journal of Engineering and Advanced Technology (IJEAT)*, 11(2), 216-221.
8. Yang, J., Tang, Y., & Yuan, Y. (2023). Design and Implementation of Li-Fi Based Automatic Billing System for Retail Applications. *Journal of Computer Science and Technology*, 38(2), 301-314.
9. Zhu, W., Tan, J., & Zhang, K. (2021). Development of an Automatic Billing System for Supermarkets Based on iot and Li-Fi Technology. *Journal of Sensors*, 2021, Article ID 8866485.
10. Ali, M. A., Rahman, M. M., & Islam, M. M. (2019). A Novel Approach to Automated Billing System Using Li-Fi Technology. In 2019 22nd International Conference on Computer and Information Technology (ICCIT) (pp. 1-6). IEEE.
11. Arora, R., Mishra, A., & Srivastava, N. (2020). A Review on Li-Fi Technology for Wireless Communication. *Journal of Engineering Science and Technology Review*, 13(5), 119-126.
12. Bhargava, A., & Choudhary, S. (2021). Design and Development of an Automatic Billing System Using Li-Fi Technology. *International Journal of Advanced Trends in Computer Science and Engineering*, 10(4), 237-241.
13. Karunaratne, T., Siriwardena, S., & Prasad, N. (2018). Integration of Li-Fi Technology in Retail Billing Systems: A Review. *International Journal of Advanced Research in Electrical, Electronics and Instrumentation Engineering*, 7(8), 8895-8900.
14. Roy, A., Chakraborty, P., & Das, S. K. (2022). Enhanced Billing System Using Li-Fi Communication for Supermarket. *International Journal of Electrical and Computer Engineering*, 12(1), 23-29.
15. Singh, P., Jain, A., & Sharma, P. K. (2023). Implementation of Li-Fi Based Automatic Billing System for Retail Stores. *International Journal of Electronics and Telecommunications*, 69(1), 67-73.